

COMPANY PROFILE

2025



Service beyond your expectation



Jaurden Services (Pty)LTD is a dynamic umbrella and multi-services company, established in 2010 in the wake of South Africa's successful hosting of the FIFA World Cup. Officially registered in 2013, the company operates with the vision of providing comprehensive, high-quality solutions across various sectors. Jaurden Services is driven by a commitment to excellence, innovation, and customer satisfaction, catering to diverse needs in both public and private sectors.



Jaurden Services has successfully extended its operations into the Democratic Republic of Congo (DR Congo) under International Engineering Services -IES, cementing its presence across Southern Africa. With a robust foundation built by supporting educational institutions like Stanford Science Academy and Oxford Little Angels, the company continues to expand and fuel its growth by partnering with various stakeholders in different industries.



Stanford Science Academy is one of the flagship divisions of Jaurden Services. It focuses on higher education, research, and project elaboration. Through this academy, Jaurden Services is empowering future leaders by providing academic programs, research opportunities, and consultancy services. Our academy partners with institutions, industries, and governments to solve real-world problems through research-driven innovation.

Key Services: Higher education programs, Mining, research consultancy, project development, academic workshops, training.



Our Vision

To deliver tailored, top-notch services that meet the evolving needs of our clients, while maintaining a steadfast commitment to professionalism, integrity, and innovation in everything we do.

Our Mission

To become a leading multi-services provider in Africa, offering reliable, sustainable, and scalable solutions to enhance the quality of life for communities and drive socio-economic development.

Why Choose Us?

- **Experience and Expertise:** With over a decade of experience, Jaurden Services is backed by a team of seasoned professionals across multiple industries.
- **Customer-Centric Approach:** We prioritize our clients' needs and are committed to delivering high-quality, innovative solutions tailored to their specific requirements.
- **Sustainability:** Our business model incorporates sustainable practices, focusing on environmental impact reduction, social responsibility, and long-term value creation.



Jaurden Services (Pty)Ltd

BRANCHES

DR CONGO

Bd Du 30 Juin,
Gombe, Kinshasa DRC

Golf Meteo
Lubumbashi DRC

SOUTH AFRICA

29 Oxford Road
Forest Town,
Johannesburg, RSA

ZAMBIA

29 Twikatani Road,
Lusaka, Zambia

CONTACT DETAILS

+27 78 606 1409

+27 11 483 0730

+243 82 185 1656

+260 76 778 2112

info.jaurdenservices@gmail.com

info.stanfordacademy@gmail.com

www.jaurdenservices.com



Our Services



NETWORK

EXTENDED AND QUALIFIED NETWORK OF SUPPLIERS



INNOVATIVE IDEAS

OPPORTUNITY TO INNOVATE WITH FOCUS ON PATENTABILITY

EXPERTISE

30+ YEARS OF EXPERIENCE
100+ DEVELOPED PRODUCTS
200+ PATENTS

COMPETITIVE TIMELINES

CUSTOMIZED PROJECT



Mining Services



Our Services

EXPLORATION AND GEOLOGY SERVICES

MINE PLANNING AND DESIGN

SURVEYING AND GIS SERVICES

DRILLING AND BLASTING SERVICES

METALLURGICAL AND PROCESSING SERVICES

ENVIRONMENTAL SERVICES

HEALTH, SAFETY, AND COMPLIANCE

PROJECT MANAGEMENT

EQUIPMENT SUPPLY AND MAINTENANCE

DIGITAL TRANSFORMATION AND INNOVATION

DRONE SURVEYING & INSPECTIONS

TECHNICAL CONSULTING

- Oil Off & Onshore Exploration
- Surface Mining
- Underground Mining

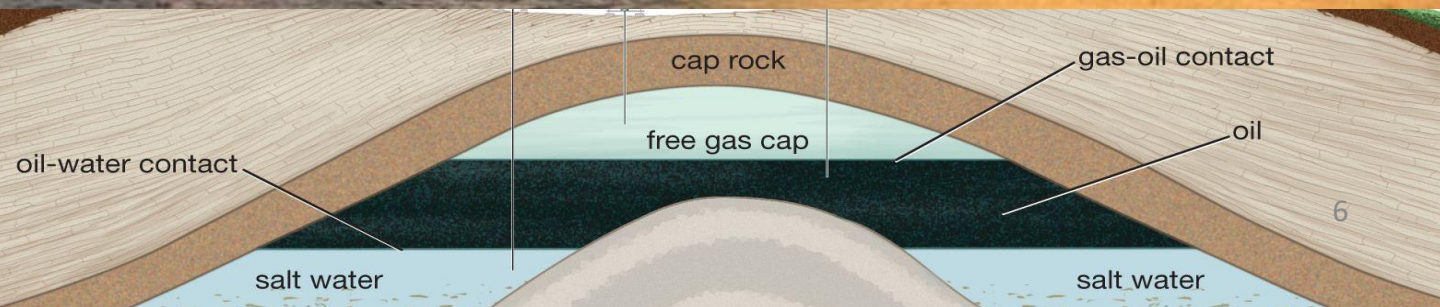



Mining Services Continued

EXPLORATION AND GEOLOGY SERVICES

- Geological Mapping & Surveys
- Geophysical and Geochemical Analysis.
- Drilling Services
- Exploration Project Management

MINE PLANNING AND DESIGN

- Mine Design & Feasibility Studies
- Resource and Reserve Estimation
- Pit Optimization & Scheduling
- Mining Method Selection

SURVEYING AND GIS SERVICES

- Mine Surveying
- 3D Modeling and GIS Mapping

DRILLING AND BLASTING SERVICES

- Drilling Solutions
- Blasting Design and Optimization
- Rock Stability Monitoring

METALLURGICAL AND PROCESSING SERVICES

- Ore Sampling and Metallurgical Testing
- Process Design & Plant Optimization
- Tailings Management

ENVIRONMENTAL SERVICES

- Environmental Impact Assessments (EIA)
- Mine Closure and Rehabilitation Plans
- Waste Management Solutions

HEALTH, SAFETY, AND COMPLIANCE

- Health and Safety Audits
- Safety Training and Risk Management
- Mine Compliance Audits

TECHNICAL CONSULTING AND PROJECT MANAGEMENT

- Mine Project Management
- Technical Due Diligence
- Data Management & Analytics

EQUIPMENT SUPPLY AND MAINTENANCE

- Mining Equipment Rental & Sales
- Maintenance and Repair Services
- Spare Parts Supply

ENERGY AND INFRASTRUCTURE SOLUTIONS

- Power Supply and Renewable Energy
- Water Management
- Infrastructure Development

DIGITAL TRANSFORMATION AND INNOVATION

- Mining Automation & Technology Solutions
- Data Integration & Monitoring
- Drone Surveying & Inspections



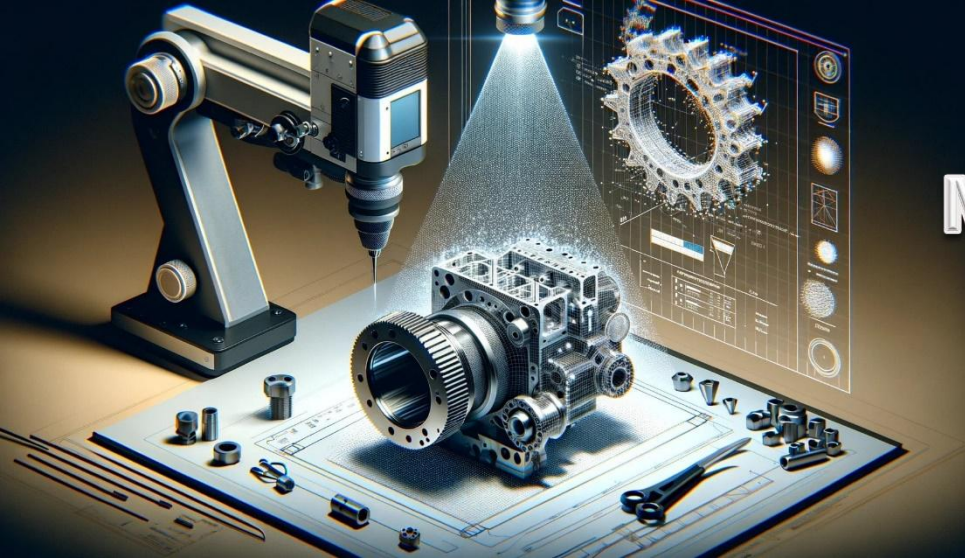

Metrology Services

Our Services

VERIFICATION OF MEASURING INSTRUMENTS

- Inspection and verification of measuring devices across various sectors (scales, thermometers, hygrometers, etc.).
- Certification and calibration of equipment to ensure accuracy and compliance with international standards.

LEGAL METROLOGY FOR GAS STATIONS (FUEL STATIONS)

- Periodic verification and calibration of fuel pumps to ensure compliance with regulations.
- Measurement and control of volumes dispensed by pumps to prevent distribution errors.
- Technical assistance and advice for maintaining equipment in fuel stations.

CALIBRATION OF PRESSURE AND TEMPERATURE INSTRUMENTS

- Calibration services for pressure gauges, thermometers, and other instruments used in industrial and commercial environments.
- Calibration of pressure sensors in quality control systems.

WEIGHING SYSTEM CONTROL

- Verification of scales used in industrial, commercial environments, and retail points to ensure weighing accuracy.
- Calibration and adjustment services for weighing systems.

CALIBRATION OF VOLUMETRIC INSTRUMENTS

- Measurement and calibration of containers and devices used to quantify volumes in industrial and commercial sectors, including the petroleum and chemical industries.

METROLOGICAL AUDIT

- Conducting audits to assess the compliance of installations and equipment with metrological requirements.
- Recommendations for improving measurement processes to optimize the quality and reliability of products and services.
- Control of Weighing Systems
- Calibration of Volumetric Instruments
- Metrological Audit



Legal Metrology



Health



Environment



Safety



Commerce



Individuals and Enterprises



OFFICE
CONGOLAIS DE
CONTROLE



SABS
ISO 9001



Scientific
Metrology



Legal
Metrology



Industrial
Metrology

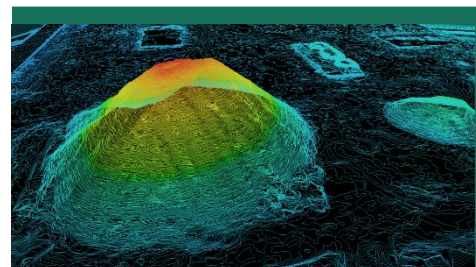

Stanford
Science Academy



Architecture & Interior Design

Our Services

ARCHITECTURAL DESIGN & PLANNING

RENOVATION & RESTORATION SERVICES

ARCHITECTURAL DESIGN & PLANNING

INTERIOR DESIGN SERVICES

LANDSCAPE ARCHITECTURE

RESIDENTIAL DESIGN

RESIDENTIAL DESIGN

LIGHTING & ACOUSTIC DESIGN

COMMERCIAL DESIGN

PROJECT MANAGEMENT

3D RENDERING & VISUALIZATION

CUSTOM DESIGN PACKAGES

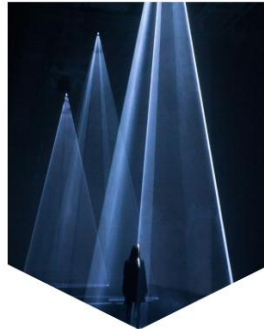

SUSTAINABILITY

DESIGN / BUILD

IMPACT

SPACES TO HEAL / GROW

FRESH THINKING

We're focused on process and execution that is mindful and responsible.

We offer a circular design approach that streamlines the process and ensures projects are completed without surprises.

Our projects are icons of creativity that help communities reimagine what spaces for humans are fully capable of.

Our projects are alive and evolve, to be a platform for the users to evolve along with them. They are intuitive and welcoming environments.

By employing emerging technology and ways that extend out of conventional architectural process and thinking.

Architecture & Interior Design

Continued



ARCHITECTURAL DESIGN & PLANNING

- Conceptual Design Development
- Space Planning & Zoning
- Site Analysis & Feasibility Studies
- 3D Modeling & Visualization
- Detailed Architectural Drawings
- Building Code & Zoning Compliance
- Sustainability & Green Building Design

INTERIOR DESIGN SERVICES

- Concept & Theme Development
- Space Layout Optimization
- Custom Furniture Design
- Selection of Materials, Finishes, and Fabrics
- Lighting Design & Integration
- Color Scheme Coordination
- Interior Styling & Decoration

RESIDENTIAL DESIGN

- Custom Home Design
- Home Renovation & Remodeling
- Kitchen & Bathroom Design
- Outdoor & Landscape Architecture
- Sustainable Home Solutions (Eco-friendly materials, energy-efficient designs)

COMMERCIAL DESIGN

- Office Space Planning & Fit-out
- Retail Store & Restaurant Design
- Hospitality Design (Hotels, Resorts)
- Educational & Healthcare Facilities
- Co-working Space Design

PROJECT MANAGEMENT

- Design Project Coordination & Supervision
- Vendor & Contractor Management
- Cost Estimation & Budget Management
- Construction Documentation & Permitting
- Quality Control & Assurance

3D RENDERING & VISUALIZATION

- High-quality 3D Renderings & Walkthroughs
- Augmented Reality (AR) & Virtual Reality (VR) Experiences
- Photorealistic Interior & Exterior Renders

FURNITURE & FIXTURE DESIGN

- Bespoke Furniture Design
- Fixture Selection & Customization
- Installation Supervision & Quality Assurance

RENOVATION & RESTORATION SERVICES

- Heritage Building Restoration
- Adaptive Reuse & Repurposing
- Modernization and upgrades structures.

LIGHTING & ACOUSTIC DESIGN

- Interior & Exterior Lighting Design
- Smart Lighting Solutions
- Acoustic Treatment & Soundproofing Solutions

LANDSCAPE ARCHITECTURE

- Garden & Outdoor Space Design
- Urban & Rural Landscape Planning
- Hardscape & Softscape Design
- Sustainable Landscape Solutions

CONSULTATION SERVICES

- Architectural Design Consultation
- Space Optimization & Renovation Advice
- Property Development Consultation
- Environmental & Sustainability Consulting

CUSTOM DESIGN PACKAGES

- Basic Conceptual Design Packages
- Full Design-to-Execution Packages
- Tailored Interior Design Services for Homeowners & Corporates
- Real Estate Staging & Showroom Design

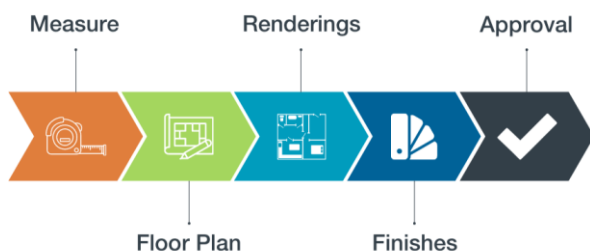

Construction Services



ROAD CONSTRUCTION SERVICES

- Road Design & Planning
- Paving & Asphalt Laying
- Road Grading & Earthworks
- Drainage Systems
- Road Signage & Marking
- Bridge & Overpass Construction
- Road Maintenance & Repairs



COMMERCIAL CONSTRUCTION SERVICES

- Commercial Building Design
- General Contracting
- Interior Fit-Outs & Renovations
- HVAC, Plumbing, & Electrical
- Green Building & Sustainability
- Car Park & Landscaping Construction
- Fire Safety & Compliance



PRIVATE HOME CONSTRUCTION SERVICES

- Custom Home Design & Build
- Home Extensions & Renovations
- Roofing, Siding & Waterproofing
- Flooring & Tiling
- Painting & Decorating
- Energy-Efficient Homes
- Driveways, Pools & Outdoor Areas
- Home Automation & Smart Systems

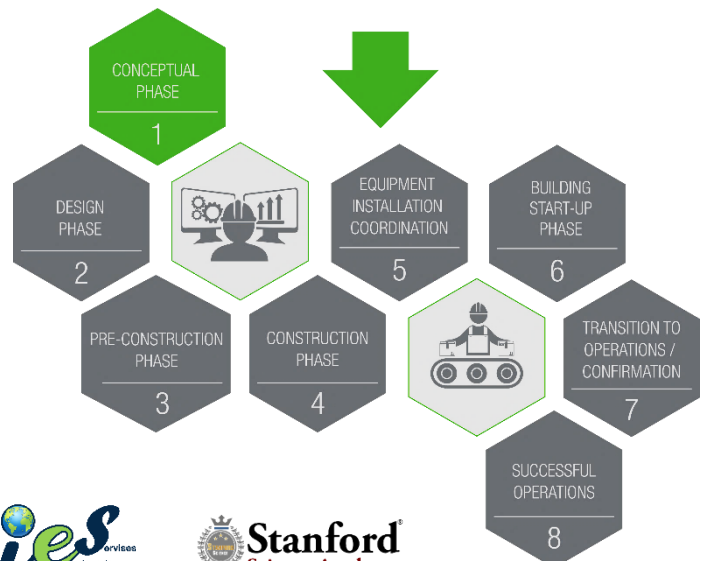
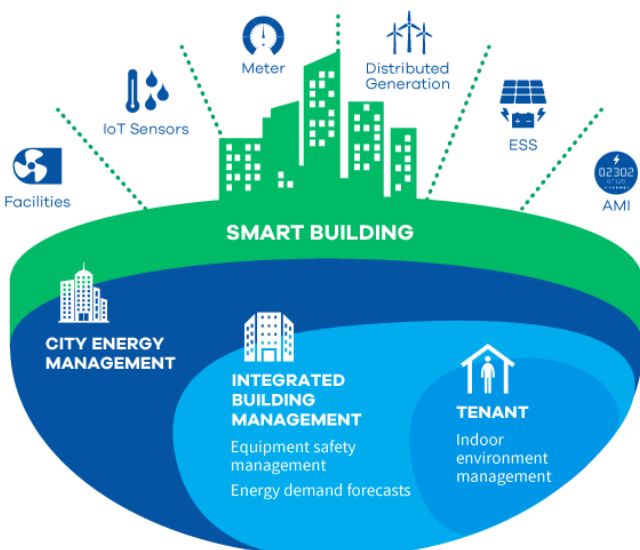

Import & Export Services

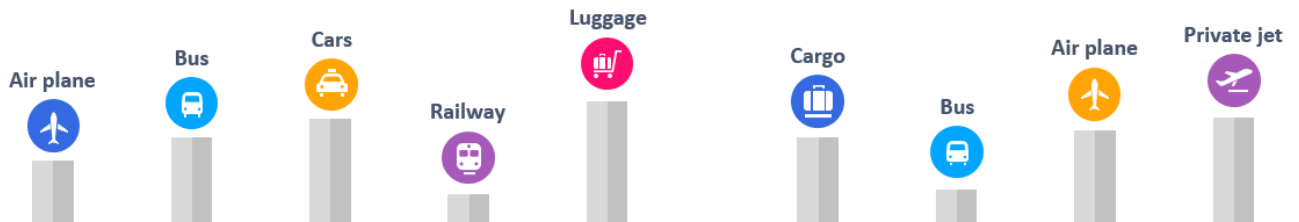

- IMPORT OF EQUIPMENT AND MACHINERY
- IMPORT OF CONSUMER GOODS
- EXPORT OF ARTISANAL CRAFTS AND TEXTILES
- IMPORT OF CONSTRUCTION MATERIALS
- EXPORT OF MINERAL RESOURCES
- IMPORT AND EXPORT OF AGRICULTURAL PRODUCTS
- IMPORT OF RENEWABLE ENERGY TECHNOLOGY





Product Distribution Services



RETAIL DISTRIBUTION

- Product placement in major supermarkets, pharmacies, and convenience stores.
- Strategic retail partnerships to ensure high visibility and customer access.

E-COMMERCE INTEGRATION

- Seamless integration with online platforms for automated order processing and delivery.
- Setting up and managing online store profiles for clients.

MARKET RESEARCH AND PRODUCT PLACEMENT

- Conducting market research to identify ideal distribution channels.
- Optimized placement of products based on consumer demand and location insights.

VENDOR MANAGEMENT

- Collaboration with suppliers, manufacturers, and logistics partners to ensure smooth product flow.
- End-to-end tracking of the supply chain from the supplier to the final point of sale.

MARKETING AND SALES SUPPORT

- Development of promotional campaigns and product demonstrations.
- Providing marketing materials such as flyers, posters, and social media content.

WAREHOUSING AND INVENTORY MANAGEMENT

- Secure storage solutions for products with real-time inventory tracking.
- Temperature-controlled and dry storage facilities.
- Stock management and replenishment alerts.

ORDER FULFILLMENT

- Fast and efficient picking, packing, and shipping of orders.
- Custom packaging options based on client preferences.
- Direct-to-customer delivery and corporate bulk shipments.

LAST-MILE DELIVERY

- Reliable, on-time delivery to retail outlets, hotels, restaurants, and other commercial clients.
- Use of multiple logistics channels (vehicles, bicycles, etc.) for flexible delivery solutions.

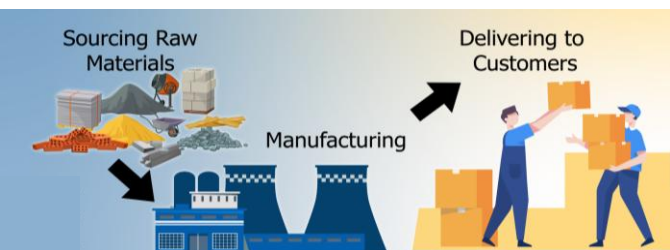
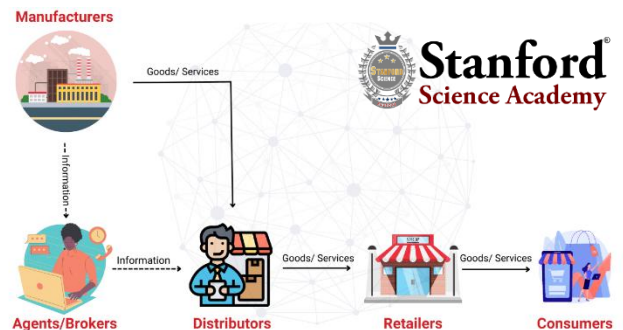

Commercial Law Services

Our Services

CONTRACT DRAFTING AND REVIEW

BUSINESS FORMATION AND STRUCTURING

MERGERS AND ACQUISITIONS (M&A)

CORPORATE GOVERNANCE

EMPLOYMENT LAW COMPLIANCE

INTELLECTUAL PROPERTY PROTECTION

COMMERCIAL LITIGATION

DEBT RECOVERY AND INSOLVENCY

REGULATORY COMPLIANCE

FRANCHISE LAW

REAL ESTATE TRANSACTIONS

TAX LAW ADVISORY

COMMERCIAL ARBITRATION AND MEDIATION

COMPETITION AND ANTITRUST LAW

Our Legal Team:

Our highly qualified legal team brings extensive experience across various legal domains in Africa, with a strong focus on OHADA law, commercial litigation, corporate governance, and contractual matters. Our expertise spans providing legal advisory services to both private and public entities, ensuring compliance with regulatory frameworks and supporting clients in complex cross-border transactions and disputes.

Our Juridical Advisor - OHADA Law Expert:

At the helm of our legal team is our esteemed Conseiller Juridique, a Doctor in OHADA law with a deep understanding of the legal intricacies in Africa's Francophone countries. With years of experience in interpreting and applying the OHADA uniform acts

Commercial Law Services

Continued

CONTRACT DRAFTING AND REVIEW:

Drafting, reviewing, and negotiating contracts, including sales agreements, partnership agreements, service contracts, and lease agreements to protect clients' interests.

BUSINESS FORMATION AND STRUCTURING:

Advising on and facilitating the formation of business entities (e.g., partnerships, corporations, LLCs), ensuring compliance with local regulations, and optimizing legal structures for tax and liability purposes.

MERGERS AND ACQUISITIONS (M&A):

Providing legal guidance on business acquisitions, mergers, joint ventures, and strategic partnerships, including due diligence, negotiation, and contract drafting.

CORPORATE GOVERNANCE:

Advising businesses on corporate governance issues, helping to ensure compliance with regulations, and developing company policies and procedures.

EMPLOYMENT LAW COMPLIANCE:

Assisting businesses in drafting employee contracts, advising on labor laws, and handling disputes related to employment, workplace policies, and wrongful terminations.

INTELLECTUAL PROPERTY PROTECTION:

Assisting businesses in protecting their intellectual property, including trademarks, patents, copyrights, and trade secrets.

COMMERCIAL LITIGATION:

Representing businesses in commercial disputes, including breach of contract claims, shareholder disputes, and conflicts over intellectual property or business competition.

REGULATORY COMPLIANCE:

Advising clients on compliance with industry-specific regulations (e.g., banking, energy, telecommunications) and helping avoid penalties for non-compliance.

FRANCHISE LAW:

Advising businesses on franchising opportunities, drafting franchise agreements, and ensuring compliance with franchising laws.

DEBT RECOVERY AND INSOLVENCY:

Assisting with the collection of outstanding debts and advising on insolvency or bankruptcy proceedings, helping businesses navigate financial restructuring.

REAL ESTATE TRANSACTIONS:

Providing legal support for the purchase, sale, and leasing of commercial real estate, including negotiation of terms and ensuring compliance with zoning laws.

COMPETITION AND ANTITRUST LAW:

Advising businesses on compliance with competition laws and defending against allegations of unfair business practices, monopolies, or price-fixing.

COMMERCIAL ARBITRATION AND MEDIATION:

Offering alternative dispute resolution services, including arbitration and mediation, to settle business disputes without going to court.

TAX LAW ADVISORY:

Providing guidance on tax law issues relevant to commercial transactions, tax planning, and disputes with tax authorities.





City Waste Management

Services



Our Services

RESIDENTIAL WASTE COLLECTION

- Door-to-Door Waste Pickup
- Bulk Waste Collection
- Recycling Services

COMMERCIAL WASTE COLLECTION

- Business & Office Waste Management
- Construction Waste Removal
- Industrial Waste Disposal

STREET AND PUBLIC SPACE MAINTENANCE

- Street Sweeping
- Public Bin Management
- Graffiti and Litter Removal

RECYCLING AND SORTING FACILITIES

- Recycling Centers
- Waste Sorting and Recycling Plant
- Composting Services

HAZARDOUS WASTE MANAGEMENT

- Medical and Clinical Waste Disposal
- E-Waste Collection
- Toxic and Hazardous Waste

ENVIRONMENTAL SOLUTIONS AND AWARENESS PROGRAMS

- Recycling Awareness Campaigns
- Educational Programs
- Sustainable Practices Consultancy



Professional Training



ADMINISTRATION COURSES ENGINEERING COURSES MANAGEMENT COURSES

- Business Management
- Project Management
- Financial Management
- Engineering Management
- Environmental Management
- Governance



Methods of Employee Training



Skills Development

Induction Training

- Guidance
- Coaching
- Computer Based Training

On the Job Training

- Guidance
- Shadowing
- Mentoring
- Coaching
- Computer Based Training

Off the Job Training

- Lectures
- Tutorials
- Computer Based Training





Stanford
Science Academy

Continuous Learning



lost d
2cc



Stanford
Science Academy

Short Course:
MINING Studies
 Certificate

Minimum Duration : 1 Day to 3 months

Theoretical studies
 Practical work experience/internship



PROGRAMME OFFERING	CODE	DURATION
Mineral Processing	MP01	1 day to 3 months
Surface Mining (Open Cast)	SM01	1 day to 3 months
Underground Mining Methods	UMM	1 day to 3 months
Surface Excavation	SE01	1 day to 3 months
Drill and Blasting	DB01	1 day to 3 months
Introduction to Mining	IM01	1 day to 3 months
Geotechnical Engineering Intro	GEIO1	1 day to 3 months
Mining Technical Support	MTS01	1 day to 3 months
Geographical Information System (GIS)	GIS01	1 day to 3 months
Environmental Mining Management	EM01	1 day to 3 months
Mine Planning & Design (levels)	MPD01	1 day to 3 months
Surface Leveling (Practical)	SLP01	1 day to 3 months
Mining Resource Management	MRM01	1 day to 3 months
Mineral Reserve Management	MRE02	1 day to 3 months
Mining Economic Management	MEM01	1 day to 3 months
Geology (Mineral)	GM01	1 day to 3 months
Mineral Reserve Evaluation & 3D Modeling (Datamine)	REM01	1 day to 3 months

Admission - Matric Level
Requirements: - N3 level

Short & Long course: **MINE SURVEYING**

Mine surveying is a branch of mining science and technology. It includes all measurements, calculations and mapping which serve the purpose of ascertaining and documenting information at all stages from prospecting to exploitation and utilizing mineral deposits both by surface and underground working. It includes the study of the geology of the deposit, the determination of positions, volumes and quantities that is used in the design, development and excavation of minerals.



Career Options:

Mine Surveyors are employed within the field of mining science and technology, with a key focus on measurements, evaluating, calculations and mapping for all stages of the mining process. It also involves organizing, operating and monitoring mining processes in conjunction with environmental protection and health and safety requirements for underground working conditions. Through technological advancements, the industry has improved production levels and safety whilst simultaneously managing environmental impact,

Career Opportunities:

- General Manager
- Mineral Resource Manager
- Surface Mining Surveyor
- Underground Mining Surveyor
- Survey Analyst
- Mine Planner
- Geospatial Engineering Consultant
- Geospatial Systems Manager
- Mine Manager

Short & Long course: **MINING ENGINEERING**

Mining Engineering technologists are involved in the daily production activities that includes the design of excavations, developing drilling patterns for the explosives, the cleaning of the broken rock and the support of excavations.



A Mining Engineer may manage any phase of the mining value chain including exploration, feasibility studies, mine design, resource reporting and rehabilitation of mining land.

Career Options:

Mining Engineering is a combination of several areas of expertise. It involves organizing, operating and monitoring mining processes in conjunction with environmental protection and health and safety requirements for underground working conditions. Through technological advancements, the industry has improved production levels and safety whilst simultaneously managing environmental impact. Strategic industry relations provide a platform for graduate. Mining Companies, software companies for planners, investment companies and more and more opportunities in consulting practices are becoming available.

Career Opportunities:

- General Manager
- Health and Safety Manager
- Mine Manager
- Miner
- Mineral Resources Manager
- Mining Engineer – Academic/Research
- Project Manager
- Rock Engineering Manager
- Sales Representative (Industrial Products)
- Superintendent
- Technical Services Manager



Stanford[®] Science Academy



Stanford[®]
Science Academy

Short & Long Course **CHEMICAL ENGINEERING**

Chemical engineering is the study and practice of transforming substances at large scales for the tangible improvement of the human condition. Such transformations are executed to produce other useful substances or energy, and lie at the heart of vast segments of the chemical, petroleum, pharmaceutical and electronic industries.



Career opportunities:

Chemical engineers work in manufacturing, pharmaceuticals, healthcare, design and construction, pulp and paper, petrochemicals, food processing, specialty chemicals, polymers, biotechnology, and environmental health and safety industries, among others.

Specialization

- Process operator
- Technician
- Laboratory (Demonstrator, technician, manager)
- Chemical engineer
- Environmental protection
- Research and development chemistry
- Quality control

Certificate: **EDUCARE**

Educare looks at the programming and instructional support that develop early skills and nurture the strong parent-child relationships that create the foundation for successful learning.



Career opportunities:

- Social worker
- Day Care Teacher
- Early childhood development Educator
- Special Education Coordinator
- Preschool Teacher Aide
- Preschool Lead Teacher

Short & Long Course: **BUSINESS MANAGEMENT**

BUSINESS MANAGEMENT is the function that coordinates the efforts of people to accomplish goals and objectives by using available resources efficiently and effectively. Business management includes planning, organizing, staffing, leading or directing, and controlling a business to accomplish the goal.



Career Opportunities:

One of the best advantages professionals gain from a career in business management is a sense of job security, because no matter where cutbacks are made, companies still need someone to stick around and run the business. While the economy recovers, and businesses start to see an increase in profits as customers return to healthier spending, general managers will also enjoy the pride that comes with being the cog in the machine that allowed for upsurges in business.



Specialization:

Some typical titles that are applied to general business managers are President, Vice President, Branch Manager, Chief Marketing Officer, Chief Financial Officer, Director and Chief Operating Officer. Specific duties of each position changes depending on the needs of the company and how it formulates its chain of command, but for the most part, a career in general management places professionals in top positions in business. They always have at least some authority over lower level managers who directly report to them.

Short & Long Course: **FINANCIAL MANAGEMENT**

Financial management refers to the efficient and effective management of money (funds) in such a manner as to accomplish the objectives of the organization. It is the specialized function directly associated with the top management. The significance of this function is not only seen in the 'Line' but also in the capacity of 'Staff' in overall administration of a company.



Career opportunities:

Financial managers' responsibilities vary according to position. Specific titles include controller, treasurer or finance officer, credit manager, cash manager, and risk and insurance manager. Controllers prepare special reports as required by regulatory authorities and oversee the preparation of financial reports, such as income statements, balance sheets, and analyses of future earnings or expenses, which describe and predict the organization's financial position. In many firms, controllers supervise the accounting, audit, and budget departments.

Short & Long Course: **END USER COMPUTING**

The qualification provides a framework for learners to develop skills that will enable them to become competent in End User Computing. It introduces theoretical and Application of End User Computing to develop a range of skills that will enable learners to be better-informed workers in their chosen industry. It provides a balanced learning experience to enable life long learning and to productive employment.



Career opportunities:

- Secretary
- Project Administrator
- Data Capturer
- Office Administrator
- Job in IT or Business environment



Certificate: **Artificial Intelligent**



The field of artificial intelligence encompasses computer science, natural language processing, coding, mathematics, data science, and many other disciplines.

Artificial Intelligence is a method of making a computer, a computer-controlled robot, or a software think intelligently like the human mind. AI is accomplished by studying the patterns of the human brain and by analyzing the cognitive process. The outcome of these studies develops intelligent software and systems.

Career opportunities:

- Data Scientist
- Machine Learning Engineer
- Research Scientists
- Big Data Architect
- Video Game and Software Programmer.



Executive Staff

At Jaurden Services, we pride ourselves on an experienced and diverse team of professionals with expertise across various industries.



Rev. Heaven E. Ndonga

Business development and Accounting, Mining Surveyor, Mineral Reserves and Resources Evaluator, Mine Planner, Researcher.

Mr. Heaven brings a wealth of knowledge in mining and resource evaluation. He is proficient in mine planning and has a strong background in research and business accounting, giving him a holistic approach to resource management and a Datamine lectures at the University of Johannesburg.



Mr Bizau Mondo

Judiciary Advisor, President of Commercial Tribunal of Haut Katanga, Doctor in OHADA's Law.

As a legal expert and a key figure in the commercial legal landscape of DRC, Dr. Mondo provides deep insights into OHADA Law, making him an indispensable asset for businesses navigating commercial law.



Mr. Christophe Nzau H Ndonga

Metrologist Engineer and Specialist.

Mr. Ndonga is an expert in engineering and metrology, ensuring precision in measurement and technical specifications in various engineering projects. Expert in petroleum and regulation industry.



Mrs. Noella Namasi Cisangani

Education Manager, Criminologist, Expert in Child and Youth Development, Business Developer.

Mrs. Cisangani is a specialist in education management, criminology, business development, child and youth development, with a strong focus on creating impactful educational programs and social initiatives.



Dr. Mpanza Mbalenhle

Geologist, Researcher, Coordinator, Lecturer.

Dr. Mpanza is a renowned geologist, expert in geostatistics with extensive research and academic experience. she has coordinated various geological projects and lectures at the University of Johannesburg.



Mr. Victor Seonja

Computer Scientist

Mr Victor is a renowned computer engineer, expert in software development, website, mobile application and AI. He coordinate the IT Department

Executive Staff

Continued



Mr. Pax Kitenge Tshomba

Business Developer, Coach, Psychologist, and Personal Development Specialist.

Mr. Tshomba specializes in guiding individuals and businesses towards success by leveraging his expertise in business development, motivational coaching, and strategic growth plans. Focus on human capital development and organizational improvement.



Mr. Jonathan Losonene Kayumba

Economist, Administrator, Accountant, and Financial Auditor

Mr. Jonathan Kayumba brings his experience in financial administration, accounting, taxation, and human resource management. His specialties include streamlining financial operations, conducting audits, and enhancing organizational efficiency through robust administrative strategies.



Dr. Efadzwa Tipoy

Medical Doctor & Hospital Manager

Dr. Efadzwa Tipoy is a skilled medical doctor and hospital manager, currently leading as government healthcare management in Johannesburg. His expertise spans clinical services, hospital administration, and healthcare strategies, ensuring efficient patient care and the management of health facilities.



Mr. Christian Caleb

Architect, Civil Engineer.

Mr. Caleb is both an architect and civil engineer, designing and overseeing the construction of commercial, industrial, and residential projects with a focus on functionality and sustainability.



Ms. Lerato Rapoo

Diamond and petrol expert.

Ms. Rapoo is highly skilled in the diamond and petroleum industry, providing expert consultation on diamond valuation, grading, and market trends.



Ms Yochin Ndonga

Interior Designer.

Ms Yochin Ndonga brings a creative edge to interior design, offering customized solutions for commercial and private spaces.



Ms. Carmel Mould

Bsc. Philosophy and Programme Management

Ms. Carmel Mould is a highly skilled professional with expertise in Programme Management. With a strong background in strategic planning, project execution, and stakeholder engagement.



Holding Structures



At Jaurden Services Holding, our strength lies in the diversity and autonomy of our subsidiaries, each specialized and highly skilled in its respective field. This structure allows us to operate across a wide range of industries, ensuring flexibility and resilience in a dynamic business environment. The independence of each company fosters innovation, agility, and a strong focus on their specific markets, while the group's support and resources enable strategic growth and operational excellence. Together, we leverage this combination of independence and collaboration to deliver exceptional value to our clients and stakeholders.

We take great pride in the remarkable journey we have built over the decades. Our diverse range of services, combined with unparalleled expertise, has not only allowed us to meet the evolving needs of our clients but also to exceed expectations across all sectors.



Our Partners

African Union



Stanford
Science Academy



SOUTH AFRICA



29 Oxford Road
Forest Town,
Johannesburg, RSA

140 West Street, Sandton,
Johannesburg, RSA

DR CONGO



Bd Du 30 Juin,
Gombe, Kinshasa DRC

Golf Meteo
Lubumbashi DRC

ZAMBIA



29 Twikatani Road,
Lusaka, Zambia

CONTACT DETAILS

+27 78 606 1409
+27 11 483 0730
+243 82 185 1656
+260 76 778 2112
info.jaurdenservices@gmail.com



Stanford
Science Academy



www.jaurdenservices.com

info.jaurdenservices@gmail.com
info.stanfordacademy@gmail.com